



## HD|Lust Connection guide



### Audio Cable Change

As of 1<sup>st</sup> January 2007 All HD cards are shipped with a universal Audio cable supporting DB15 pin male cable configuration.

### Digital Audio I/O

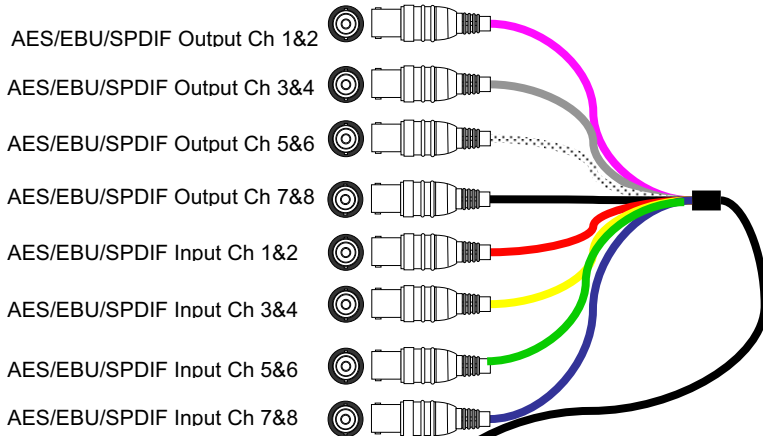

### Ancillary Interfaces

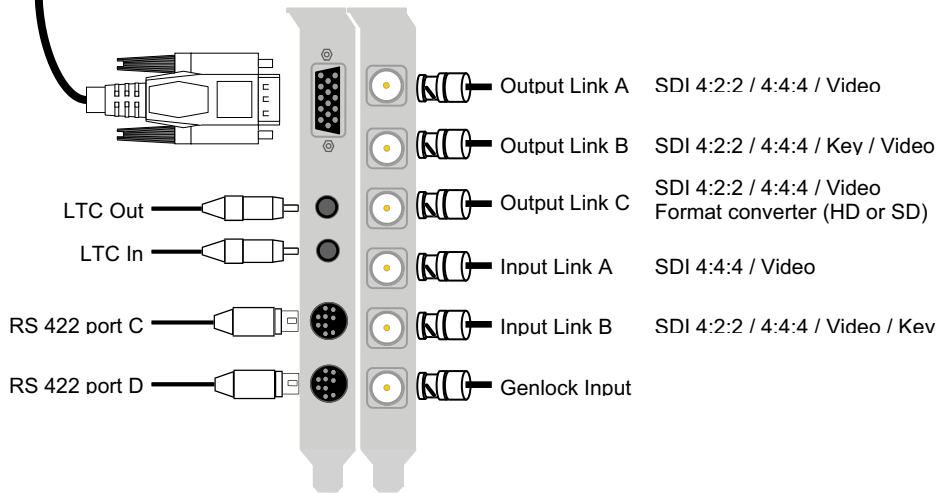

### SDI Video I/O

RS 422 ports are for OEM only  
Symmetry and Premiere Pro does not support the SD Greed RS 422 port, Please use the COM port.

### Note

- For Single 4:2:2 input the SDI cable must be placed on the Input link B.
- For Dual link 4:4:4 input/output you require two cables in both link A and Link B ports.
- For Dual link 4:4:4:4 Video and Key, Video is Link A, Key is Link B.
- For internal keyer, the input must be on link B.
- Output Link C can be switched when in HD modes to output SD SDI via the simultaneous hardware down conversion, or an HD-SDI video output. When in SD video modes, output C is a 3rd SD SDI video output.
- When in SD video modes all HD-SDI will be switched to SD-SDI.
- RS 422 ports are not used with certain applications such as Adobe Premiere Pro or Symmetry